

Multiport EDFAs for FTTx Networks

Up to 64 Output Ports, Up to 21dBm per Port Output Power, Supports SNMP



DATASHEET

BUY NOW

The EDAR Series are low-noise, high-performance Erbium-Doped Fiber Amplifiers (EDFAs) that provide the ideal building blocks for FTTx networks. It can amplify both analog and digital signals up to 100GHz. Integrated CWDM splitters are available to enable the routing of 1310 nm and 1490 nm data streams from the OLT to the ONU through the EDFA, reducing component count, lowering the FIT rate, and improving system performance. The EDAR Series provides a robust and reliable amplification solution for FTTx networks using RF video overlay. We provide solutions to handle mid to small-sized municipal networks while meeting the demanding requirements of large Tier 1 service providers. Our team of engineers and scientists will work with you to customize configurations.

The EDFA has isolators on both input and output.

These Erbium-Doped Fiber Amplifiers (EDFAs) are engineered for a long operational lifespan, typically designed to function reliably for over 10 years. This durability is achieved through high-quality components and robust manufacturing processes. The design considerations include thermal management, component selection, and rigorous testing to maximize the amplifier's longevity and efficiency.

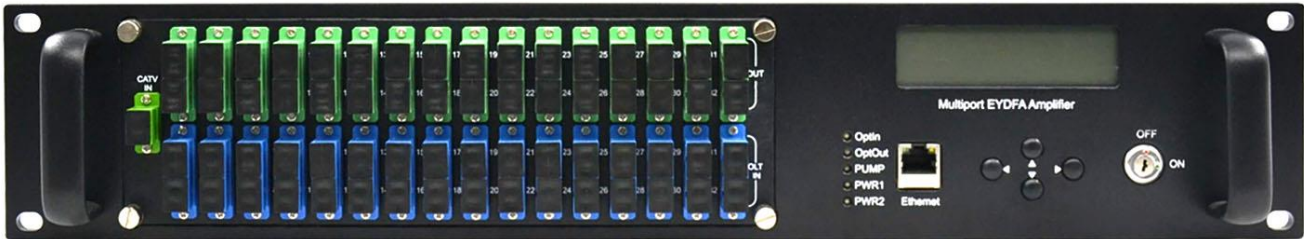

Features

- Up to 64 Output Ports
- Up to 23 dBm per Port Output Power
- Daisy Chain Ports for Future Expansion
- Integrated CWDM Splitter Option
- Support SNMP
- Redundant Power supplies
- Cool-Free Pumps for Low Power Consumption

Applications

- RF over Fiber
- FTTx Networks

Specifications

Parameter	Min	Typical	Max	Unit
Operating Wavelength	1540		1560	nm
Number of Ports	4	32	64	
Output Power per Port	17	21	23	dBm
Port to Port Variation	0.25		1.5	
1550nm Input Power	-5		10	dBm
Monitor Port Output Power	0		3	dBm
Noise Figure (Input = 6 dBm)			4.5	dB
Carrier to Noise Ratio Degradation		1		
Residual Pump Power			-30	dBm/m
Daisy Chain Output Power	9		10	dBm
Operating Temperature	-40		65	°C
Storage Temperature	-40		85	°C
Electrical Power Input AC	100		220	VAC
Electrical Power Input DC	40		50	VDC
Power Consumption			70	W
Size	19" mount rack			

Notes:

* Pre-amplifier output power is limited to 25dBm

Note: The specifications provided are for general applications with a cost-effective approach. If you need to narrow or expand the tolerance, coverage, limit, or qualifications, please [click this link](#):

Legal notices: All product information is believed to be accurate and is subject to change without notice. Information contained herein shall legally bind Agiltron only if it is specifically incorporated into the terms and conditions of a sales agreement. Some specific combinations of options may not be available.

Rev 08/29/24

© Photonwares Corporation

☎ +1 781-935-1200

✉ sales@photonwares.com

🌐 www.agiltron.com

Information contained herein is deemed to be reliable and accurate as of the issue date. Photonwares reserves the right to change the design or specifications at any time without notice. Agiltron is a registered trademark of Photonwares Corporation in the U.S. and other countries.

Multiport EDFAs for FTTx Networks

Up to 64 Output Ports, Up to 21dBm per Port Output Power, Supports SNMP



DATASHEET

System Diagram (Typical)

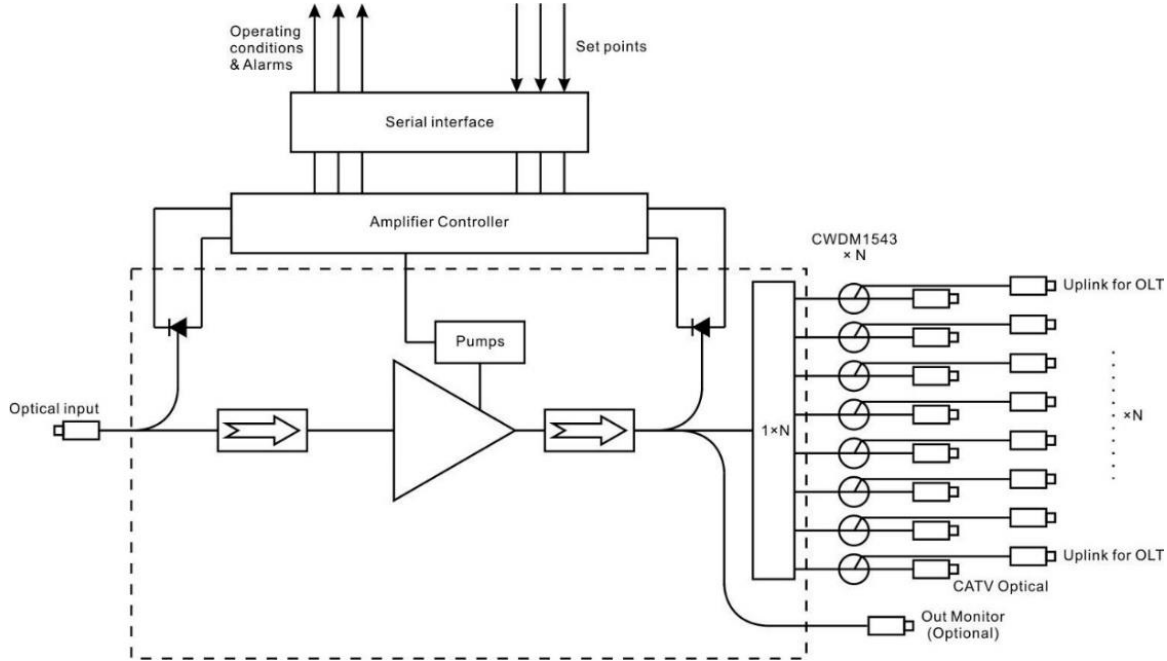

Ordering Information

Prefix	Type	Wavelength	Power ^[1]	Channel	Package	CWDM	Electric	Connector ^[2]
EDAR-		1550nm = 5 Special = 0	21dBm = 1 20dBm = 2 17dBm = 3 23dBm = 4 Special = 0	4 = 04 12 = 12 16 = 16 18 = 18 20 = 20 24 = 24 32 = 32 64 = 64	2U = 2 3U = 3 4U = 4	No = 1 Yes = 2 Special = 0	110-220V = 1 48DCV = 2	LC/PC = 7 FC/PC = 2 FC/APC = 3 SC/PC = 4 SC/APC = 5 LC/APC = 9 LC/UPC = U Special = 0

[1]. For Booster, Power means maximum output power. For Preamp, Power means maximum amplification gain.

[2]. Regular connector only rated to 0.5W and will burn at higher power. We make a special beam expanded connector to handle up to 5W

Note:

- Pre-amplifier output power is limited to 25dBm
- For >1W modules, the fiber cables extrude out of the front.

Multiport EDFAs for FTTx Networks

Up to 64 Output Ports, Up to 21dBm per Port Output Power, Supports SNMP



DATASHEET

Control GUI

Multiport EDFAs for FTTx Networks

Up to 64 Output Ports, Up to 21dBm per Port Output Power, Supports SNMP



DATASHEET

Modes Description

The EDFAs have both ACC mode - automatic current control or constant current control and APC mode - automatic power control settable via GUI. In the ACC mode, the pump laser's current is set by the user and automatically locked by the EDFA to achieve a constant pumping current. The EDFA's output power is proportional to the input power and has output even though the input signal is weak. In the APC mode, the user sets the output power, and the EDFA automatically maintains the output constant in a feedback laser pump control way. When the input optical power fluctuates, the APC mode minimizes the fluctuation of the output power and is suitable for power type and line type EDFA.

Application Notes

Fiber Core Alignment

Note that the minimum attenuation for these devices depends on excellent core-to-core alignment when the connectors are mated. This is crucial for shorter wavelengths with smaller fiber core diameters that can increase the loss of many decibels above the specification if they are not perfectly aligned. Different vendors' connectors may not mate well with each other, especially for angled APC.

Fiber Cleanliness

Fibers with smaller core diameters (<5 μm) must be kept extremely clean, contamination at fiber-fiber interfaces, combined with the high optical power density, can lead to significant optical damage. This type of damage usually requires re-polishing or replacement of the connector.

Maximum Optical Input Power

Due to their small fiber core diameters for short wavelength and high photon energies, the damage thresholds for device is substantially reduced than the common 1550nm fiber. To avoid damage to the exposed fiber end faces and internal components, the optical input power should never exceed 20 mW for wavelengths shorter 650nm. We produce a special version to increase the handling by expanding the core side at the fiber ends.

Laser Safety

This product meets the appropriate standard in Title 21 of the Code of Federal Regulations (CFR). FDA/CDRH Class 1M laser product. This device has been classified with the FDA/CDRH under accession number 0220191. All versions of this laser are Class 1M laser products, tested according to IEC 60825-1:2007 / EN 60825-1:2007. An additional warning for Class 1M laser products.

For diverging beams, this warning shall state that viewing the laser output with certain optical instruments (for example, eye loupes, magnifiers, and microscopes) within a distance of 100 mm may pose an eye hazard. For collimated beams, this warning shall state that viewing the laser output with certain instruments designed for use at a distance (for example, telescopes and binoculars) may pose an eye hazard.

Wavelength = 1.5 μm .

Maximum power 1W.



*Caution - Use of controls or adjustments or performance of procedures other than those specified herein may result in hazardous radiation exposure.

*IEC is a registered trademark of the International Electrotechnical Commission.